

# Diesel Generator Sets



## C250D6

Our energy working for you.™



### Standard Genset Features

Cummins water cooled Diesel engine.  
Oil and fuel filter fitted, water separator.  
Lube-oil drain valve fitted.  
Electric starter and Charge alternator 24 VDC.  
Electronic governor,  
Normal duty air filter.  
Single bearing alternator.  
Set mounted starting battery.  
Engine, Alternator, Chassis and Control Command House color: Munsell Jade Green.  
Radiator and Guarding in color: Black.  
Packing under shrunk plastic film.  
Operation and Maintenance manual.  
Standard set of labels.  
Fuel tank in skid - day tank.

### PMG (Permanent Magnet Generating)

Offers enhanced motor starting, good performance with nonlinear loads and fault clearing short circuit capability.

### Warranty Standard

Warranty 2 years (Standby) or 1 year (Prime Power)

### Exhaust Options

Exhaust silencer - industrial 9 dB(A).  
Exhaust silencer - Residential 29 dB(A).

### Warranty

Warranty 5 years extended - (Standby)  
Warranty 2 years extended or 6000 hours - (Prime)

### Fuel Consumption

### Generator Set Performance

#### Voltage Regulation

Maintains voltage output within  $\pm 1,0\%$  in the following conditions:

1. At any power factor between 0.8 and 1.0.
2. At any load level from no load to full load.
3. At speed droop variations up to 4,5%.

#### Frequency Regulation

Isochronous under any load from no load to 100% full load.

#### Random Frequency Variation

Will not exceed  $\pm 0,25\%$  of rated frequency value for constant loads, from no load to full load.

### Compliance Standards

To BS4999/5000 pt 99,  
VDE 0530, UTE5100,  
NEMA MG1-22, CEMA,  
IEC 34, CSA A22.2,  
AS1359, BSS 5514,  
ISO 3046 and ISO 8528

### Generator Set Options

#### Options

Coolant heater  
Battery Charger  
Automatic Transfer Switches - GTEC  
Silencer Enclosures  
External Tank  
Heavy Duty Air Filter

### Alternator Specification

#### Type

Brushless single bearing, revolving field, four pole.  
Protection from water (dripping).  
Class H Insulation, IP23 Protection  
Vacuum impregnation.  
IC 01 cooling system.  
Fully interconnected damper winding.  
AC exciter and rotating rectifier unit.  
Epoxy coated stator winding.  
Rotor and exciter impregnated with polyester resin appropriate to the tropical climate, resistant to oil and acids.  
Rotor balanced dynamically BS 5625 2,5 degrees.  
Permanent lubricant ball bearing  
Rotor wound in layers and with mechanics coins.

#### Exciter

Triple dipped in varnish resistant to oil and acid.  
Coated with anti-tracking varnish.

#### Winding

Low reactance 2/3 pitch windings; low waveform distortion with non-linear loads, fault clearing short-circuit capability.  
Engine/alternator direct coupling for perfect alignment.

### Voltage Connections - 60 Hz

480/277 V 380/220 V 220/127 V  
440/254 V 240/139 V 208/120 V  
416/240 V

Ratings	Standby				Prime			
	313 kVA	250 kW			281 kVA	225 kW		
Load	Full	3/4	1/2	1/4	Full	3/4	1/2	1/4
Consumption (L/hr)	67	50	34	18	59	45	31	17

#### Observation:

The engine above was tested according to the ISO-3046 respecting the following conditions:

Barometric Pressure = 100 kPa (29.83 in Hg)

Altitude above sea level = 110 m (316 ft)

Ambient temperature = 25° c (77° F)

Relative humidity = 30%

## Technical Data

<b>Model</b>	<b>C250D6</b>	<b>Alternator voltage regulation</b>	± 1,0%
<b>Standby Rating</b>	250 kW / 313 kVA	<b>Alternator insulation class</b>	H
<b>Prime Rating</b>	225 kW / 281 kVA	<b>IP Protection</b>	IP 23
<b>Engine Manufacturer</b>	Cummins	<b>Fuel consumption (Standby)</b>	67 l/h
<b>Engine Model</b>	QSL9-G5	<b>Fuel consumption (Prime)</b>	59 l/h
<b>Cylinders</b>	6 cylinders	<b>Lubrication system oil capacity</b>	22,7 l
<b>Engine Build</b>	In line	<b>Coolant capacity (only engine)</b>	11 liters
<b>Standard Governor/Class</b>	Electronic	<b>Coolant capacity (engine and radiator)</b>	29 liters
<b>Aspiration and cooling</b>	Turbocharged	<b>Exhaust temperature (Prime)</b>	500°C
<b>Bore and stroke</b>	114 mm x 145 mm	<b>Exhaust gas flow (Prime)</b>	930 l/s
<b>Compression Ratio</b>	16,8 : 1	<b>Exhaust gas back pressure max</b>	76 mm Hg
<b>Cubic capacity</b>	9 liters	<b>Air flow radiator</b>	9.47 m³/s
<b>Starting/Min °C</b>	Unaided / -12°C	<b>Intake air flow</b>	390 l/s
<b>Battery capacity</b>	100 A/h (2x)	<b>Minimum air opening to room</b>	1.73 m²
<b>Gross Engine output – Standby</b>	355 kWm	<b>Minimum discharge opening</b>	1.45 m²
<b>Gross Engine output – Prime</b>	307 kWm	<b>Radiated heat to ambient</b>	35 kWm
<b>Speed</b>	1800 rpm	<b>Tank incorporated in the base capacity</b>	400 Liters

### STANDBY POWER RATING

The Standby Power Rating is applicable for supplying emergency power for the duration of a utility power interruption. No overload, utility parallel or negotiated outage operation capability is available at this rating. In installations served by unreliable utility sources (where outages last longer or occur more frequently), where operation is likely to exceed 200 hours per year, the prime power rating should be applied.

### PRIME POWER

Prime power is available for an unlimited number of annual operating hours in variable load applications, in accordance with ISO8528-1. A 10% overload capability is available for a period of 1 hour within a 12-hour period of operation.

### All ratings are based on the following reference conditions:

- Ambient temperature: 27°C

- Altitude above sea level: 150 meters

- Relative humidity: 60%

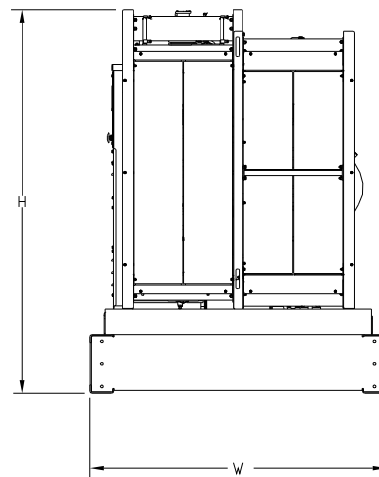
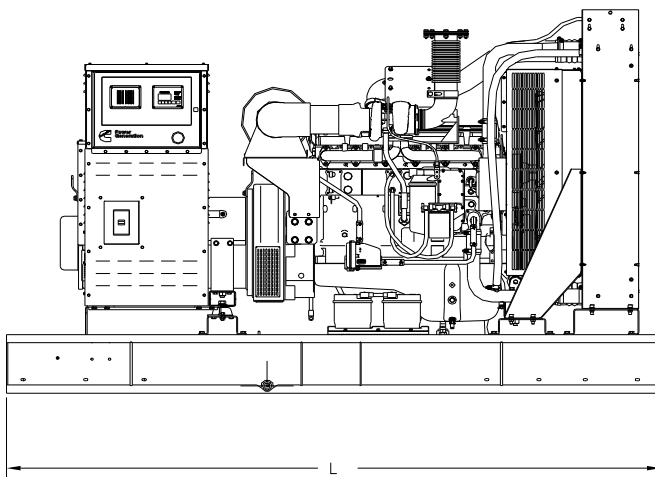

This outline drawing is for reference only. Do not use for installation design

## Dimensions and Weights

Generator Set	Length (mm) L	Width (mm) W	Maximum Height (mm) H	Set weight dry (kg)	Set weight wet <sup>1</sup> (kg)
Open Set	3000	1360	1874	2121	2536
Enclosed Set - F190	4251	1414	2316	3155	3538

<sup>1</sup>Set weight wet represent a set with oil, fuel and coolant liquid.



Cummins Brasil Ltda.  
Rua Jati, 310 - Cumbica  
Guarulhos - SP - Brasil  
Zip Code: 07180-900  
Phone: (55 11) 2186-4195  
www.cumminspower.com.br

the  
**Power**  
of One

See your distributor for more information.

